

APOLLO mini 30 安裝線路圖

解碼驅動板

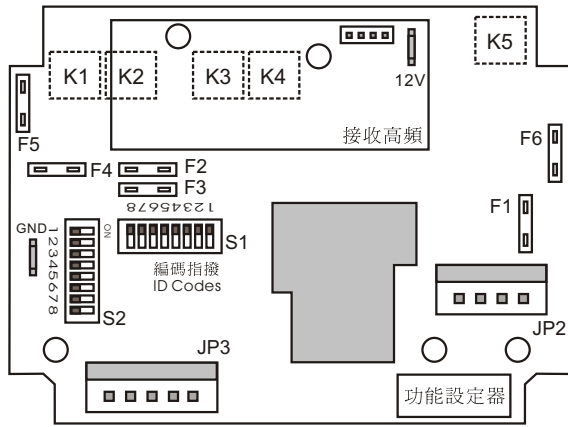

S1: 密碼指撥
S2: 功能設定
F1: 15A保險絲
F2~F6: 5A保險絲

接線位置圖

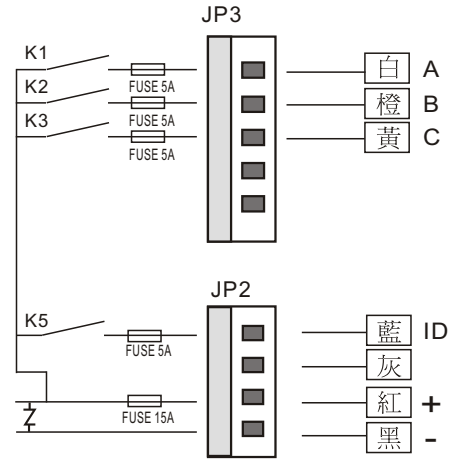

接收器

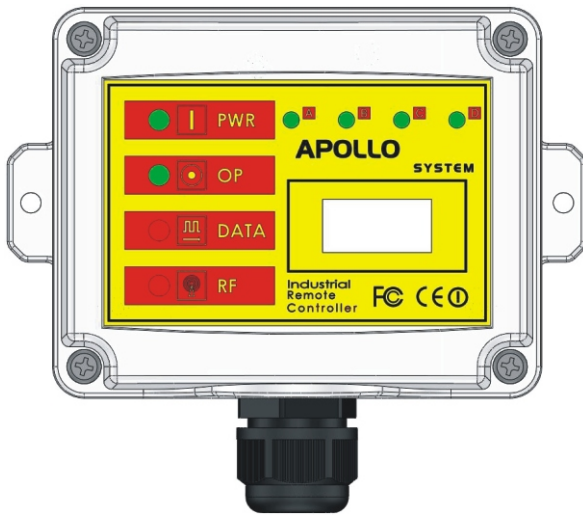

發射器

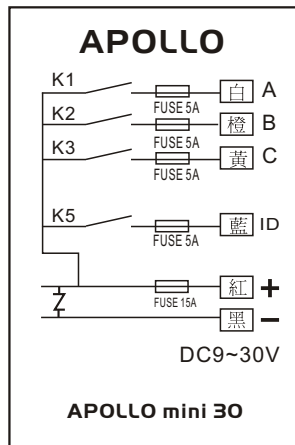
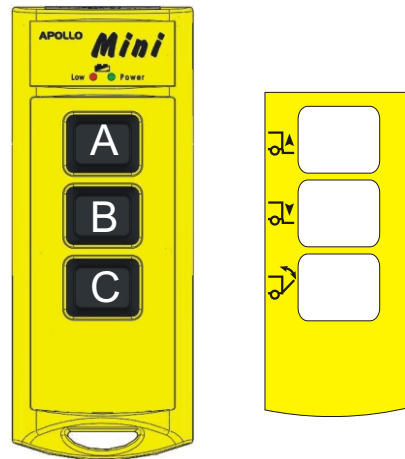

規格:

- 1.ID動作設定為<1速聯動>.
- 2.控制電纜為2M長.
- 3.面版貼紙為油壓車專用.